

**MARY QUEEN OF THE HOLY ROSARY
EXTRAORDINARY MINISTER OF HOLY COMMUNION GUIDELINES
September 2008**

Extraordinary ministers of Holy Communion are assigned by Mass times to either Team A, B or C. Each team will have a designated captain (s) and sacristan (s). The teams will alternate weekends. This is a very important ministry and we ask that you attend and serve with your team on your weekend and sign in 15-20 minutes before Mass begins. The bulletin will note which team is to serve each weekend. The bulletin board and monitor will list the team members serving at the mass.

If you are unable to attend Mass when your team is scheduled, please call and arrange for a substitute. It is your responsibility! A list of extraordinary ministers, their phone numbers and e-mail accounts will be provided to you.

Extraordinary ministers whose team is not scheduled to serve at the Mass may volunteer to serve if positions are open on the clipboard 10 minutes before the beginning of Mass.

Extraordinary ministers are not assigned to teams for Holidays and Holy Days at this time. A captain and sacristan will be assigned for these Masses in the future.

Before mass:

- Arrive 15 – 20 minutes before Mass begins and visit the Eucharistic Chapel to prayerfully prepare for your ministry.
- When you arrive for Mass, please check the extraordinary minister of Holy Communion sign in sheet on the counter in front of the bulletin board in the gathering space. Please sign your name to open host or cup positions. All host positions will be filled first, then cup positions. If a deacon is vesting for the Mass, he will take position C 3. The captain will be available to assist you.
- The captain, sacristan and H3 are asked to place their initials next to their names.
- The Captain arrives 30 minutes before Mass and checks to see...
 - That all the stations / positions are filled.
 - That the sacristan duties are completed.
 - That the number of ciboria and chalices on the credence table just before mass begins reflect the number communion ministers signed in for the Mass.
 - That the proper numbers of hosts are carried forward at the Presentation of Gifts – you will have to remain in the back of the church as the Mass begins. You will have to check the number of reserved hosts in the tabernacle to determine the number of hosts to be brought forward. Do not allow anyone to add to the bowl of hosts after you determine the amount needed.
 - That the reserved hosts from the tabernacle are placed on the altar during the Lamb of God. Leave the lid on the ciborium and join the other EM's at the base of the steps.
- The Sacristan arrives 30 minutes before Mass and checks to see...

- That the hosts are placed on the three small tables in the back of the church and that the wine is poured into the pitchers to be brought forward at the Preparation of Gifts.
- That the hosts get replenished, as necessary, at the small tables.
- That the credence table is prepared.
- That the corporal is on the credence table, not on the altar.

- Positions are depicted on this diagram:

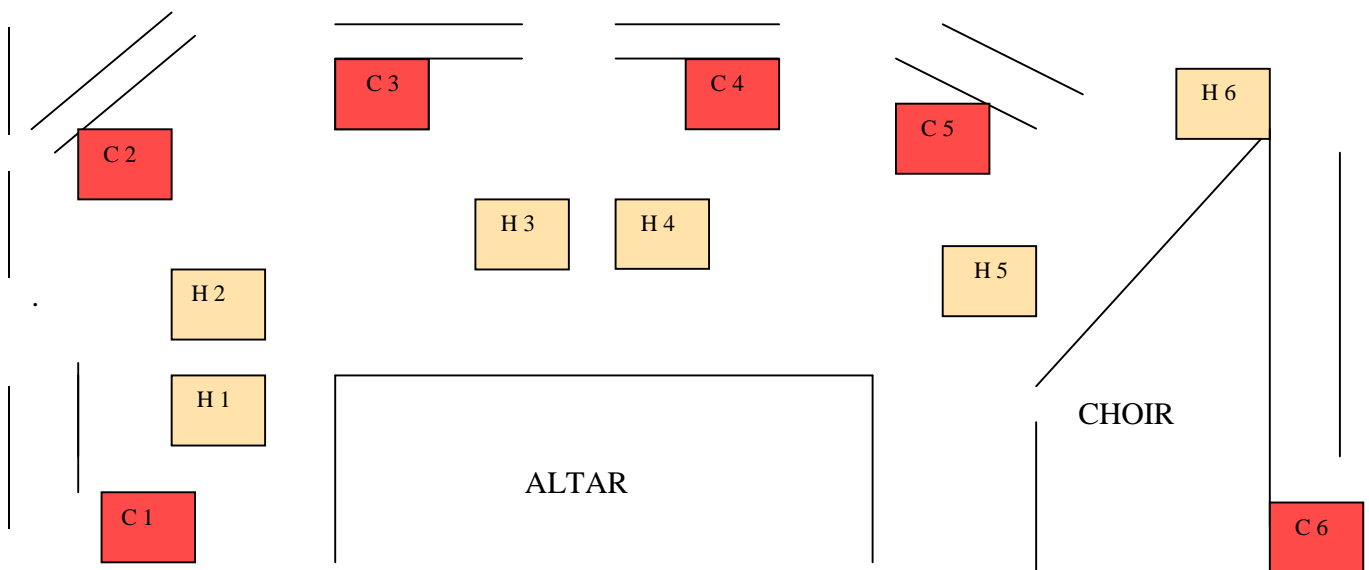

During Mass:

- Participate actively in the singing, gestures and responses.
 - Set an example by your reverence, demeanor and attire.
- The captain is responsible to bring the reserved hosts from the tabernacle and place them on the altar during the Lamb of God. Leave the lid on the ciborium and join the other EM's at the base of the steps.
- After the sign of the peace (at the Lamb of God) promptly approach the side steps of the altar. Ministers of the cup are to line up facing the steps on the choir side of the altar. Ministers of the host are to line up against the back wall at the foot of the steps on the opposite side of the altar.
- *After the priest receives the Body of Christ*, all are to come up at each side of the altar and form a semi circle, with your hands appropriately folded.
- The priest will first distribute the Body of Christ to those on the cup side of the altar and then to those on the host side of the altar.

- If a deacon or an installed acolyte is present, he will distribute the Precious Blood, following the priest, usually from the priest's chalice.
 - If a deacon or installed acolyte is not present, the priest will designate the first person to receive the Body of Christ to also receive the Precious Blood and distribute following the priest, usually from the priest's chalice.
- When all on the altar have received, the priest will begin handing out chalices and purificators to the cup ministers who will immediately proceed to their position by way of the front steps of the altar. No "Thank you" is to be given. He will hand the small ciborium to the captain who will immediately proceed up the center aisle to distribute to those in the back of church who are unable to approach the altar. He will then hand out the remaining ciboria to the host ministers who will immediately proceed to their position by way of the front steps of the altar. Ministers will begin to distribute communion after the priest reaches his position.

During the Communion Procession:

- If Precious Blood is spilled immediately cover it with a purificator. After Mass reverently clean the area with water and purificators. Precious Blood ministers cover the cup with a purificator when walking to your position and when returning to the altar.
- When distributing the Eucharist – be present to the people and touch them, but don't say their names - look at the eyes of the recipient, who should have bowed his/her head while approaching the Eucharist, saying:
 - "The Body of Christ" – as you place the Host in his/her palm or on their outstretched tongue, or
 - "The Blood of Christ" – as you hand the cup to them at a convenient height for the recipient. After taking back the cup, wipe the rim of the cup, which has touched their lips with the unfolded purificator, and rotate the cup ¼ turn for the next person.
 - The recipient's response should be, "Amen".
 - When someone approaches with crossed arms simply touch him or her on the forehead or shoulder. Do not make the sign of the cross, especially with words over someone – this is reserved to the ordained.
- Body of Christ ministers, who may run short of consecrated hosts, should look first to the captain at the altar who will bring consecrated hosts to them, and then to the extraordinary minister standing beside them. Extraordinary ministers of Holy Communion should not break the host unless told it is necessary to do so by the captain.
- As soon as you have finished distributing Holy Communion,
 - See if you are needed at another position, if so go there
 - If not, immediately place your vessel and purificator on the altar
 - DO NOT give yourself Communion by consuming either sacred species
 - Do not leave the altar, rather line up as you do to receive Holy Communion
- Wait for the priest, deacon or installed acolyte to purify the vessels
 - He will combine the Body of Christ in the covered ciborium.
 - He may consume some of the Body of Christ

- You may be offered the Body of Christ to consume, receive it; don't take it
- He will put the remaining particles of the Body of Christ into one chalice.
- When it is ready, the covered ciborium will be given to the captain or deacon
 - The captain or deacon led by a server with a candle will go immediately to the Eucharistic Chapel.
 - After reserving the Blessed Sacrament, both return to their seats.
- If you are the first minister to return to the altar get the water cruet from the credence table.
 - Uncap the water cruet and holding it, stand next to the altar. Do not place the cruet on the altar!
 - The priest, deacon or installed acolyte will take the cruet as needed and hand it back to you to return to the credence table.
- After the Blessed Sacrament has been taken to the tabernacle, the priest, deacon or acolyte
 - Will consume the remaining Precious Blood and any pieces of the Body of Christ contained in the Precious Blood.
 - You may be offered some Precious Blood to consume, receive it; don't take it.
- After consuming the Sacred Species, the priest, deacon or installed acolyte
 - Will carefully pour a very small amount of water into the vessels and consume the ablution.
- The priest, deacon or installed acolyte will wipe each vessel with a purificator.
- Only after the vessels have been wiped with a purificator,
 - Will the extraordinary ministers be handed the vessels to take to the credence table.
 - Do not try to take the vessel you used – you may have to take one or two vessels.
 - Return to your seats.
- The priest, deacon or installed acolyte will fold the corporal and give it to the last extraordinary minister who places it on the credence table.

After Mass:

- Everyone helps to take the vessels and purificators to the Sacristy.
 - Soak the purificators in the bowl that is in the Sacramentarium.
 - Wash the vessels in warm soapy water, rinse and dry them. Do not immerse the chalices/cups into the water.
 - After 4 PM Mass on Saturday and the 5:30 PM Mass on Sunday put them away.
 - After the Sunday morning masses set the credence table for the next mass. The credence table will be checked by the sacristan before mass begins.

Thank you for your participation in this Ministry.

Updated September 1, 2008